



MESH



3250216

MESH Floor H. 800 mm - LED 3000K 87°

Lighting information

Source power type	LED
Colour temperature	3000K
CRI	>90
MCADAMS	3
LM 80/TM-21	L80B10@>60Kh

Source power	10,00 W
Nominal flux	1050 lm

Plug-in power	12,00 W
Real flux	295 lm
Maximum intensity	545 cd/klm
Beam angle	87°

Power Supply Unit	220 ÷ 240V
Operating frequency	50/60 Hz
Power factor	0,95
Dimmable	Not dimmable
Safety class	I
Wiring	External
Cable section	3 x 1,00 mm ²
Cable length	3.000 mm;
Cable type	H05RN-F
Connector	IP44 shuko plug

Protection Rating	IP65
Breaking Strength	IK 07

Energy efficiency class	A/A+/A++
Diffuser type	Polycarbonate
Diffuser thickness	3 mm

Colours

Standard colour

.02 White .09 Bronze

Colours available on request

.07 Corten .08 Anthracite



Platek®

PLATEK s.r.l.
Via Paderno, 19 | 25050 Rodengo Saiano (BS) ITALY
P.IVA 03320290178 | Codice fiscale 03007130176
Registro delle Imprese di Brescia n. 03007130176 REA 311057
Capitale sociale Euro 1.000.000,00 i.v. Società con unico socio

Last update:11/02/2022



Product features

Aluminium alloy base and ground attachment. Head manufactured from milled steel and base in die-cast aluminium EN 44300 with very low copper content. Rod made of stainless steel. Polycarbonate opal diffuser screen. No visible screws. Subjected to galvanic anodizing treatment divided into distinct phases: mechanical satin finishing, surface degreasing, anodic oxidation and final sealing. The product is painted following a continuous two step paint process (epoxy-based primer + polyesterbased colour finish), which allows to generate a single thick protective coating which then generates a protective barrier against atmospheric agents and UV rays.

Technical dimensions

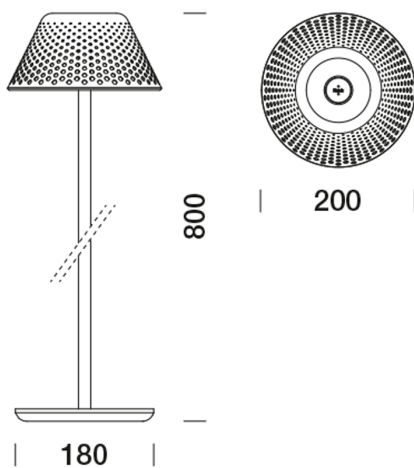

Technical shipping information

Net weight	2,70 kg
Gross weight	4,50 kg
Packaging width	930,00 mm
Packaging height	240,00 mm
Packaging depth	250,00 mm

3250216

MESH Floor H. 800 mm - LED 3000K 87°

Lighting information

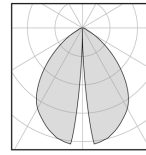

Plug-in power	12,00 W
Real flux	295 lm
Maximum intensity	545 cd/klm
Beam angle	87°

Lighting Simulation

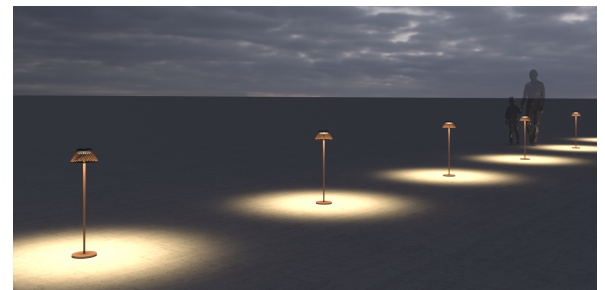

h. 800 mm

simulation made with MESH Piantana H. 800 mm 12,0 W 3000K

Optics:	87°
Code:	3250216
Distance between products:	3 m

Plug-in power	12,00 W
Real flux	295 lm
Maximum intensity	545 cd/klm
Beam angle	87°

Platek®

PLATEK s.r.l.
Via Paderno, 19 | 25050 Rodengo Saiano (BS) ITALY
P.IVA 03320290178 | Codice fiscale 03007130176
Registro delle Imprese di Brescia n. 03007130176 REA 311057
Capitale sociale Euro 1.000.000,00 i.v. Società con unico socio



MESH

3250216

MESH Floor H. 800 mm - LED 3000K 87°

Mechanical accessories

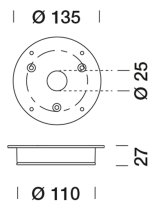

9005165
Floor fixing plate

Platek®

PLATEK s.r.l.
Via Paderno, 19 | 25050 Rodengo Saiano (BS) ITALY
P.IVA 03320290178 | Codice fiscale 03007130176
Registro delle Imprese di Brescia n. 03007130176 REA 311057
Capitale sociale Euro 1.000.000,00 i.v. Società con unico socio

Last update:11/02/2022



MESH

3250216

MESH Floor H. 800 mm - LED 3000K 87°

Electrical accessories

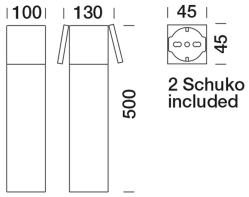

8910502
Service post H 500 mm (.08 anthracite)

Platek®

PLATEK s.r.l.
Via Paderno, 19 | 25050 Rodengo Saiano (BS) ITALY
P.IVA 03320290178 | Codice fiscale 03007130176
Registro delle Imprese di Brescia n. 03007130176 REA 311057
Capitale sociale Euro 1.000.000,00 i.v. Società con unico socio

Last update:11/02/2022



MESH

3250216

MESH Floor H. 800 mm - LED 3000K 87°

The process of galvanisation and multi-coating protection

Platek goes well beyond the standards required for conventional protection processes, making use of its longstanding and in-depth expertise in aluminium alloys. All the aluminium components of the products - extruded, die-cast or turned - are subjected to a galvanic anodizing process in the phase following mechanical processing. The process increases their wear resistance and improves the adhesion of the paint. Galvanization involves three distinct phases: mechanical satin finishing and surface degreasing, anodic oxidation and fixing. After the first phase that eliminates any impurities, the aluminium body is immersed in special electrolytic tanks, in which the aluminium surface is transformed into aluminium oxide, which makes the metal more resistant. To respond optimally to the needs of the global market, all Platek products undergo a two-layer painting process. After preparation with washing and rinsing in accordance with the strictest environmental standards, the product is coated with an epoxy primer which guarantees, in addition to anodizing, an excellent degree of protection. The final step is the preparation of the polyester powder which gives the final velvety finish of the component. These last two phases, being done in a continuous cycle, form a single high-thickness layer that is resistant to the action of UV rays and atmospheric agents. This process allows corrosion resistance in salt fog that far exceeds the average standards of the market to be achieved.

Precise LED selection

All LEDS used by Platek, once assembled by trusted personnel are tested with suitable instruments to check the colour specification required by Platek standards. The choice of using only 3 McAdams colour steps and with a CRI value exceeding 90, provide a high level of light quality that is difficult to find in the world of outdoor lighting. As far as LED products are concerned, Platek has adopted a system of protection against electrostatic discharge along the entire production chain of electronic components to increase the resistance of circuits to power surges.

Platek®

PLATEK s.r.l.
Via Paderno, 19 | 25050 Rodengo Saiano (BS) ITALY
P.IVA 03320290178 | Codice fiscale 03007130176
Registro delle Imprese di Brescia n. 03007130176 REA 311057
Capitale sociale Euro 1.000.000,00 i.v. Società con unico socio

Last update:11/02/2022